

# *RCOMP - Redes de Computadores (Computer Networks)*

*2025/2026*

## *Theoretical-practical lesson 01*

- Transmission cables and physical medium.
- Network topologies.
- Structured cabling.

# Transmission cables

Transmission cables are used to transport signals between network nodes. The cable type (transmission medium) must be appropriate for the signal being transported.

Optical signals, when not sent through empty space or transparent air, require an optical fibre. Electric and low-frequency electromagnetic signals require a good electrical conductor like copper. Although not often used, sound waves would require sound conducting material like air or water.



Optical fibre cables

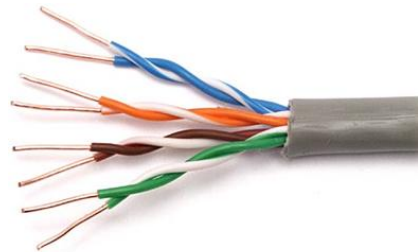

Twisted pairs copper cables



Coaxial copper cable

Optical signals sent through optical fibre cables have some major advantages over electric and electromagnetic signals sent through copper cables: lower attenuation, immunity to external noise, and also, they don't create external noise. Therefore, optical fibre cables can achieve higher data rates at longer distances without the need of repeaters. They are also very thin and cheaper.

# Copper cables

Copper cables are used for electric and electromagnetic signals. They allow a range of signal frequencies starting from zero (they support digital signals).

The big issue with electric signals is they generate electromagnetic radiation (EMR) that propagates through space. This electromagnetic radiation will then spread and appear in other nearby copper cables that will work pretty much like antennas. This is called EMI (Electromagnetic Interference).

As the electric signal frequency increases, the signal will tend to propagate better through space than through the copper itself. EMI raises two issues:

- External noise – all nearby electronic equipment spreads electromagnetic radiation that will appear in the cable as noise.
- Tapping – by listening to electromagnetic radiation an intruder may infer the original electric signal and thus will gain access to data being transmitted.

When using copper cables, EMI will always be a big concern: avoid irradiating EMR to the exterior and avoid external EMI to appear as noise on our cable.

# Copper cables - electromagnetic shielding

One approach to avoid EMR problems is shielding, this comprises surrounding the electric conductor (copper cable) with other electric conductor creating a Faraday cage effect. **Coaxial copper cables** use this approach:

In the image, we can see the inner copper cable through where the signal passes, surrounded by an insulator and a conductor shield made of an aluminum foil and a mesh.

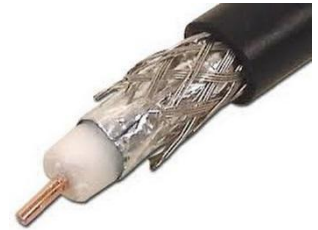

First local area Ethernet networks did use coaxial copper cables as a shared transmission medium, at 10 Mbps rate generating a 10 MHz signal.

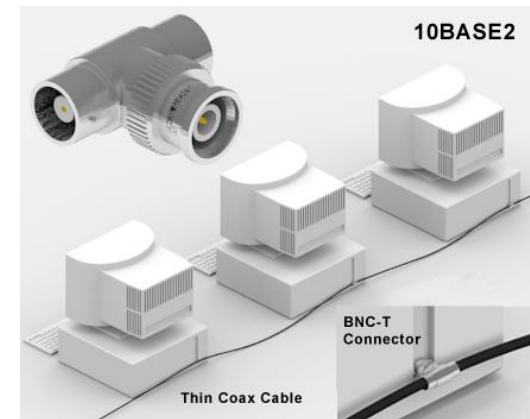
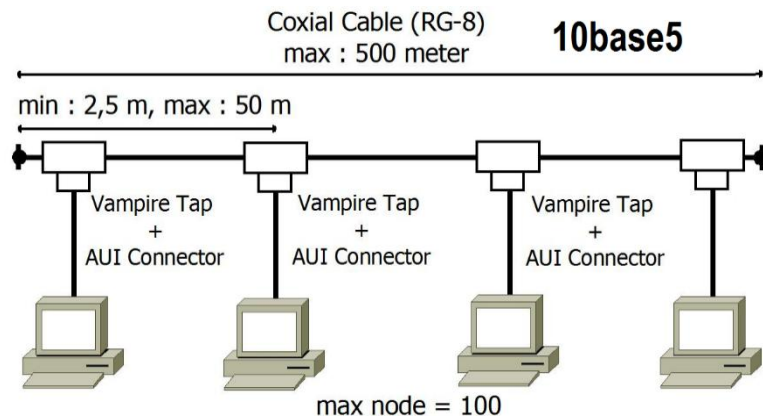

Coaxial cables are still used for many applications whenever high frequency signals are involved, for instance in cable television (CATV) and external antenna connections.

# Copper cables – balanced transmission

One different approach to avoid EMR problems is **balanced symmetric differential transmission**.

## Balanced lines with differential transmission

On a coaxial cable, the receiver measures the signal with no specific reference, in other words with reference to the ground or to the average value of the signal. In a balanced transmission, two copper cables are required to transmit a single signal, one contains the signal itself and other the reference.

The receiver measures the transmitted signal as the **difference between the two cables**, the two cables are wired as closely as possible, to ensure this, they are twisted on each other making what is called a **twisted pair (TP)**.

Because they are closely wired to each other, any external EMR interference (noise) will be **equal on both the cables** and thus will **not appear when the receiver measures the difference between them**.

This will avoid external EMR interference (external noise), however it does nothing about the noise the cables are generating to the exterior.

# Copper cables – balanced transmission

Although balanced differential transmission solve the external noise issue, something else must be done to avoid the lines themselves spreading noise to the exterior.

## Balanced lines with symmetrical differential transmission

These transmission systems are similar; however, the emitter injects the **signal in one cable** and the **symmetric signal on the other cable**. By doing so, two opposite EMR signals will be generated along the wires that will cancel each other.

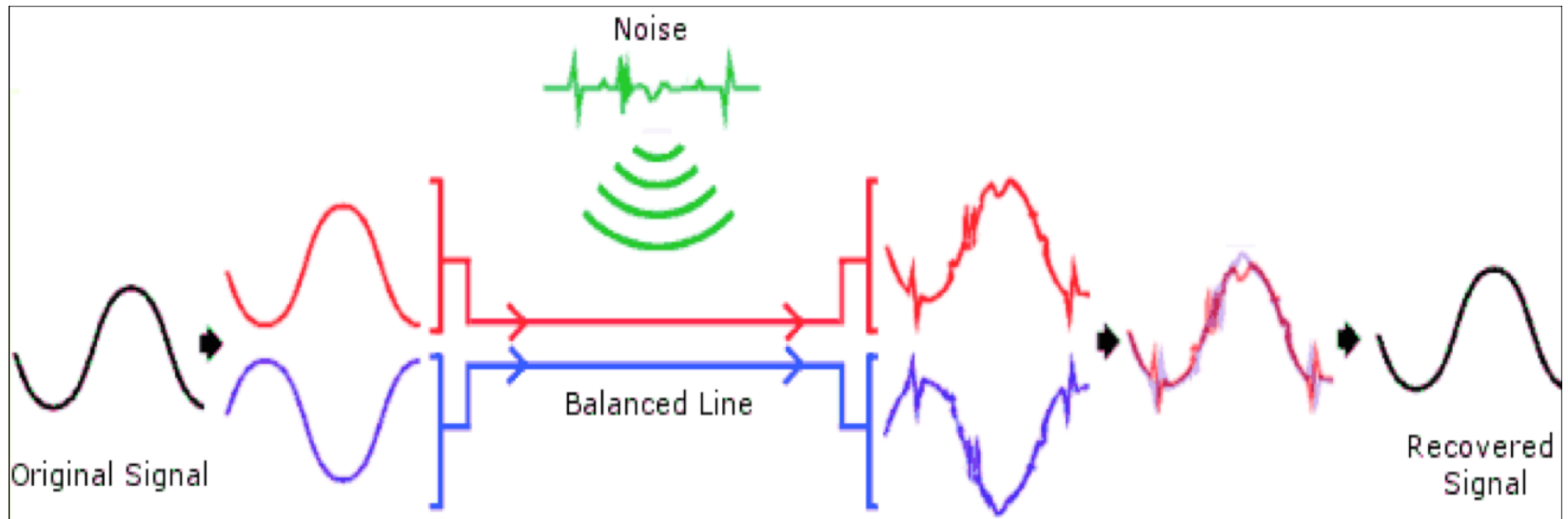

Shielding and balanced lines are not incompatible techniques; some twisted pair copper cables also use shields for additional protection.

# Optical fibre cables

Optical fibres are able to conduct light in a similar way electric conductors conduct electricity. To achieve that they are made of two transparent glass or plastic materials:

The **core** is very thin, ranging from 3 to 60  $\mu\text{m}$  (micrometers) in diameter, it's used as the propagation medium for the light signal. A **cladding layer** surrounds the core making a total exterior diameter of 125  $\mu\text{m}$ . The cladding layer aim is keeping the light within the core; this is accomplished by using a lower index refraction material. When the light from the core reaches the cladding layer, is reflected back to the core.

Signal attenuation is considerably lower than with electric signals, there are however some issues. The main one is **dispersion**. Separate fractions of the light signal will follow slightly different reflection paths lengths along the fibre and thus they will not reach the receiver at the same time. Dispersion limits the data rate that can be used and especially the maximum cable length because the longer the cable is, the most diverse will tend to be the different reflection paths lengths.

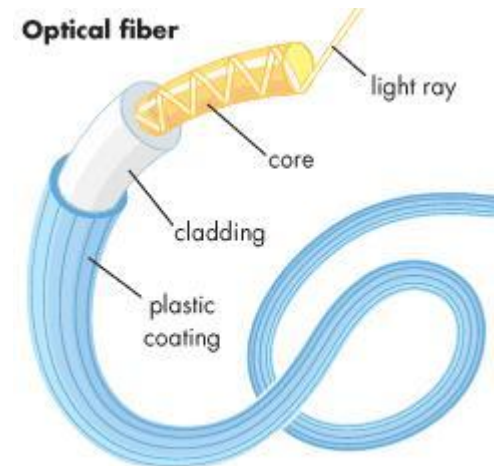

© 2006 Encyclopædia Britannica, Inc.

# Optical fibre cables - dispersion

Light dispersion along an optical fibre can be reduced and even eliminated by using a thinner core as this will result in the different reflection paths lengths becoming more similar. Below a 10  $\mu\text{m}$  core diameter, dispersion entirely disappears due to being so close to the light wavelength. Accordingly, two types of optical fibre can be identified:

**Multimode optical fibre** – core diameter above 10  $\mu\text{m}$ , usually 50  $\mu\text{m}$  or 62,5  $\mu\text{m}$ . It is affected by dispersion and thus allowing lower data rates and especially lower cable lengths, up to some hundreds of meters.

**Monomode optical fibre** – core diameter below 10  $\mu\text{m}$ , usually from 3  $\mu\text{m}$  to 10  $\mu\text{m}$ . It is immune to dispersion and thus allowing higher data rates and especially longer cable lengths, several thousands of meters.

Some other practical issues arise from using optical fibre, the first has to do with most current end user hardware not providing an optical connection. This somewhat limits its use to backbones. Backbones are heavy data flows parts of a cabling system that are not directly connected to end users' outlets.

The other practical issue is about cable mounting, due to the very thin diameter, and the required optical signal transfer instead of a simple electric signal transfer, mounting and connecting optical fibres is rather challenging.

# Network topologies – bus and ring

The way network nodes are wired together into a network is called the network topology. The first local area networks were designed to be as cheap as possible, most of them didn't have any active devices other than end nodes.

The shared medium **bus topology** (image on the right) was used on first Ethernet networks. Of course, it has all problems related to a shared medium, but it was also very unreliable because any electrical problem along the bus would make the entire network fail.

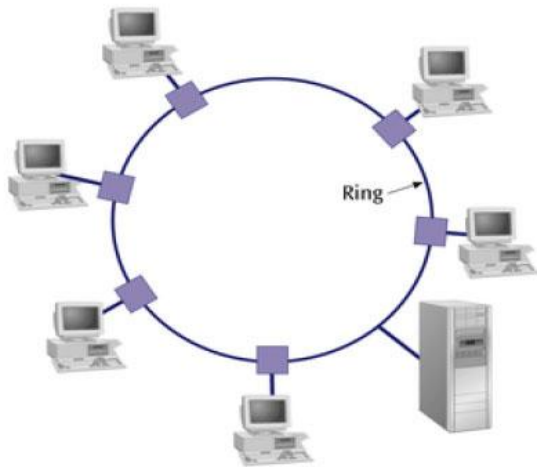
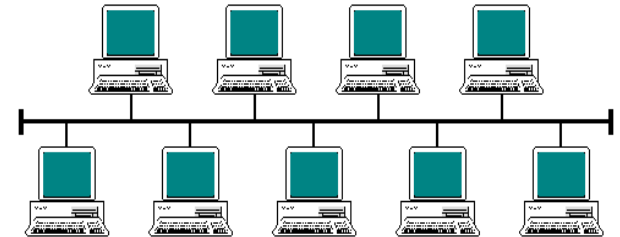

The **ring topology** (image on the left) was another option used. Each node has two connections, one to the previous node and another to the next node. Each node is supposed to retransmit data. If a node is powered off, it's out of the ring as the two connections would then be internally connected to each other. Token passing medium access control (MAC) networks like Token-Ring (IEEE 802.5) and FDDI (Fibre Distributed Data Interface) use this topology.

# Network topologies – star

Previous topologies have one common issue: reliability. One electric or mechanical problem anywhere would make the entire network out of order. The **star topology** solves this issue by introducing **cable concentrator devices**.

The cable concentrator provides electric separation between segments of cable and thus an electrical or mechanical problem in one cable affects only the node connected by that cable. Bear in mind, by itself this topology doesn't mean we don't have a shared transmission medium anymore.

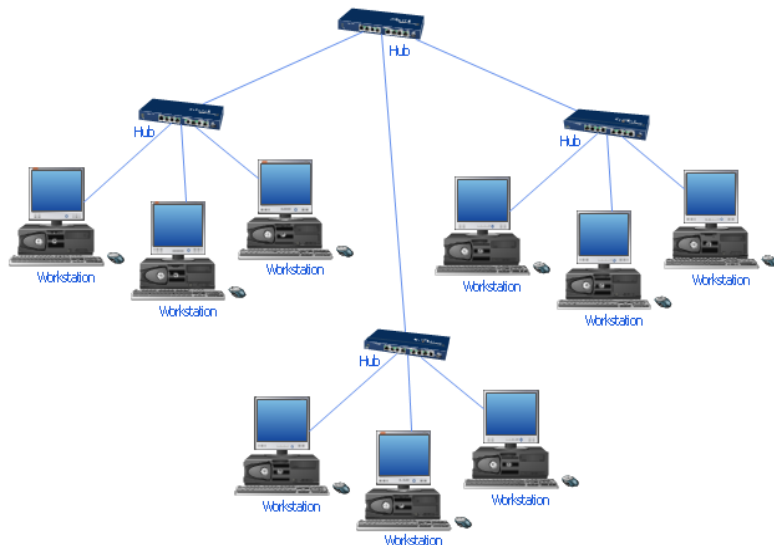
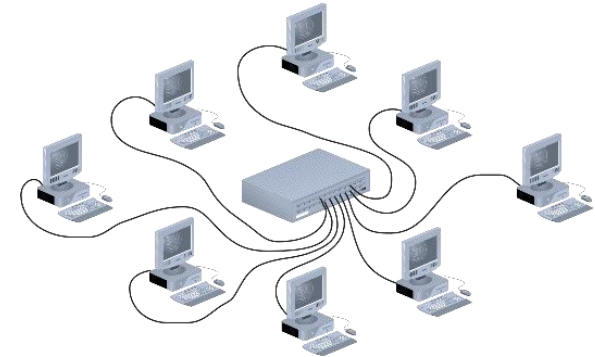

Stars can also be interconnected to become an **extended star topology**. Of course, now a failure in a cable connecting two stars will disturb more nodes.

Yet, if the cable concentrators simply amplify and repeat the signals they receive to all connected cables, this is still a **shared transmission medium**.

# Structured cabling

Communication cables are not the kind of hardware that can be changed with low cost and low general impact. Therefore, when a cabling system is installed, we want to be sure it can accomplish its mission effectively for some time.

A cabling system should not be designed with one specific layer 2 technology in mind, layer 2 technologies evolve fast and consequently corresponding layer 1 (cabling) requirements change as well. **Replacing layer 2 technology devices is easy, replacing cables is not.**

The way an engineer defends himself from this is by using **structured cabling standards**. The approach is effective because new layer 2 evolutions also obey the same structured cabling standards.

Structured cabling standards, as the name states, refers to cables and cable connectors only, they are used for planning the entire network infrastructure. This includes the places to store active equipment (concentrators, hubs, access points, switches, routers, servers, and workstations) **but not the active equipment itself**. Structured cabling standards are spread along several documents issued by TIA (Telecommunications Industry Association), ANSI (American National Standards Institute), IEC (International Electrotechnical Commission), ISO (International Organization for Standardization), and CELENEC (European Committee for Electrotechnical Standardization).

# Structured cabling – backbones

Ultimately, the main objective of structured cabling is spreading network cable connections to every place where they are required. For this purpose, three successive levels of cable distribution points are defined, they are known as cross connects or distributors:

**Main cross-connect (MC), Distributor C (DC) or Campus Distributor (CD)** – this is the single, and highest level, cable distribution point. Cables starting here made up the **Cabling Subsystem 3**, also called **campus backbone**, each cable is connected to an intermediate cross-connect.

**Intermediate cross-connect (IC), Distributor B (DB) or Building Distributor (BD)** – this is the second cable distribution level, often there is one IC per building, the cables connecting to the next level are the **Cabling Subsystem 2**, also called **building backbone** or **vertical backbone**, each cable is connected to a horizontal cross-connect.

**Horizontal cross-connect (HC), Distributor A (DA) or Floor Distributor (FD)** – usually this is the lowest level cable distribution point, cables beyond this point are no longer a backbone, they are called **Cabling System 1** or **horizontal cabling system** and provide cable connections to end user outlets at the work area on the floor.

# Structured cabling – backbones

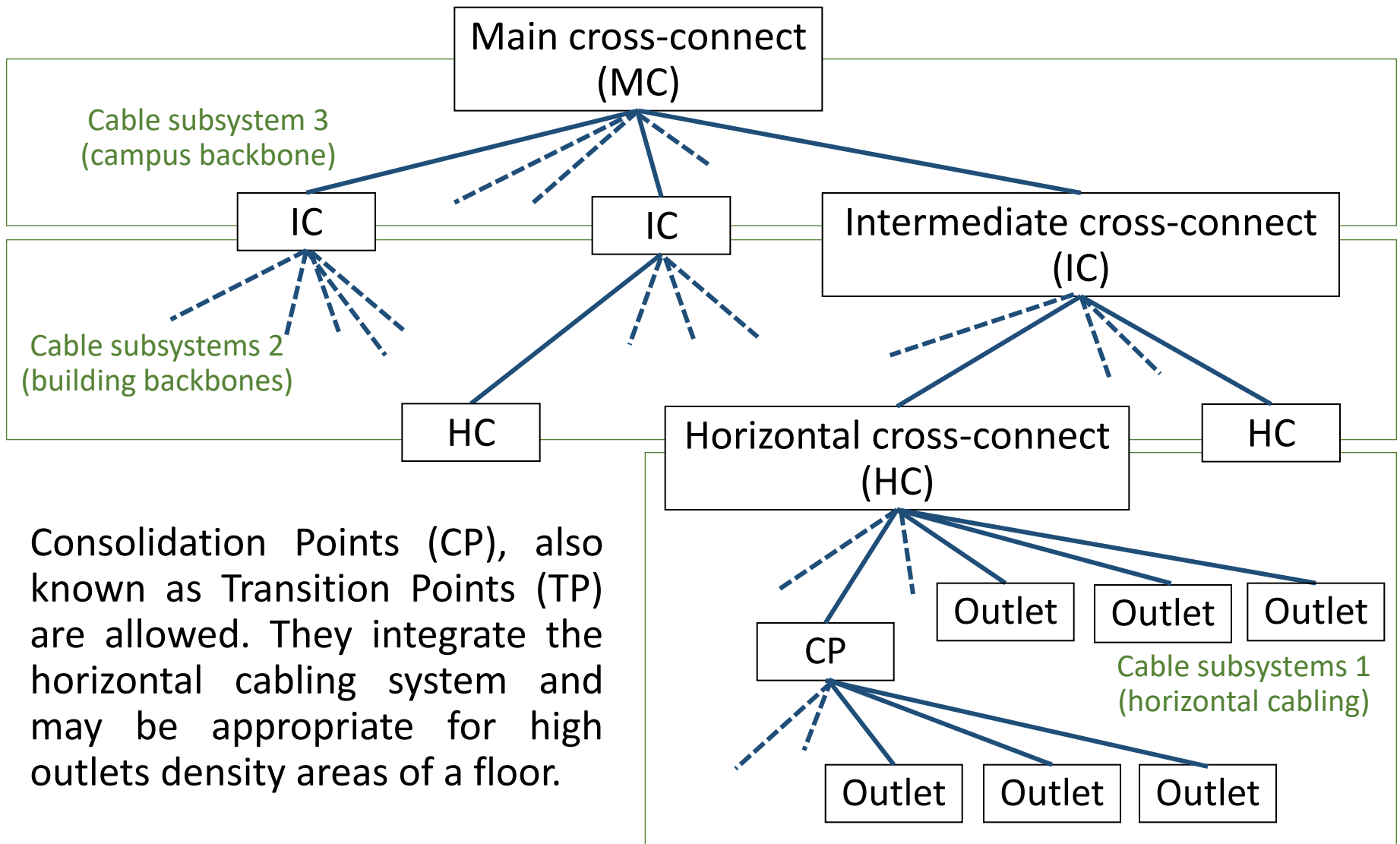

Consolidation Points (CP), also known as Transition Points (TP) are allowed. They integrate the horizontal cabling system and may be appropriate for high outlets density areas of a floor.

# Structured cabling - subsystems

Structured cabling standards also define **six subsystems**:

**Entrance Facilities (EF)** – this is the interface point to the external world, it's where the infrastructure connects to external communication systems like the internet and public switched telephone network (PSTN). It can be viewed as the starting point of the cabling system.

**Equipment Room (ER)** – environment controlled central physical location (room) that hold the wiring termination hardware and the main active equipment. Often it houses the main cross-connect (MC).

**Telecommunications Rooms (TR) and Telecommunications Enclosures (TE)** – environment controlled secondary locations (rooms) that hold the wiring termination hardware and active devices. They typical hold an intermediate cross-connect (IC) or a horizontal cross-connect (HC). May also be replaced by a telecommunications enclosure in a non-dedicated room.

**Backbone Cabling Subsystems** – As seen before, it includes two cable subsystems: Cabling Subsystem 3 (campus backbone) and Cabling Subsystem 2 (building backbone).

**Horizontal Cabling Subsystems** - Cabling Subsystems 1 (horizontal cabling).

# Structured cabling - Work Area Subsystems

**Work Area Subsystems (WA)** – The work area (WA) is made of end-user outlets for equipment's connection; each outlet is connected by a cable to a horizontal cross-connect (HC) or a Consolidation Point (CP).

Structured cabling standards specify a minimum of two outlets per work area, and also a ratio of two outlets for each 10 square meters of area. Therefore, for a work area between 10 m<sup>2</sup> and 20 m<sup>2</sup>, four outlets should be available and for an area between 20 m<sup>2</sup> and 30 m<sup>2</sup>, six outlets should be available.

Cables, called patch cords, up to five meters long will be provided to end-users to connect their equipment to outlets. Also, part of the work area, multiuser telecommunications outlet assemblies (MUTOA) may be provided, in this case, internal cable length must be discounted from the five meters limit.

Outlets' location within the work area should be such that end user equipment is in reach using the **up to five meters long patch cords** and also provide flexibility for users being able to move their equipment. Wherever the user equipment is, **there should always be an outlet less than three meters away.**

Common work areas require **copper cable outlets**. This comes from common end-user equipment not supporting fibre connections. If **fibre cable outlets** are adopted, it's likely most users will ask for fibre/copper adapters.

# Structured cabling – telecommunications enclosures

Wiring termination hardware should be housed in appropriate telecommunications enclosures. They are placed in equipment rooms (ER) and telecommunications rooms (TR) to support distribution points: main cross-connect (MC), intermediate cross-connect (IC), horizontal cross-connect (HC) and eventually Consolidation Points (CP). Also, telecommunications enclosures in non-dedicated rooms may be used for horizontal cross-connect (HC) and Consolidation Points (CP).

The most common equipment in computer networks uses the 19" rack format, it can be directly inserted into the same format telecommunications enclosures (image).



One thing to bear in mind is that these enclosures will house not only the wiring termination hardware but also active equipment that is not part of the cabling system itself like switches, routers, servers, UPS (Uninterruptible Power Supply), etc.

The exact size of telecommunications enclosures cannot be derived from the cabling system only; it must also take in account space for other hardware. Also, a 100% oversizing is wise to accommodate new hardware and upgrades.

# Structured cabling – cable types

Structured cabling standards specify three types of cables:

**Copper cable:** 4-pair 100-ohm unshielded or shielded twisted-pair, this can be either CAT6A or CAT7. Each pair is identified by a unique colour: orange, green, brown and blue. A copper cable can never be longer than 90 meters. Depending on upper layer technologies this usually allows up to 10 Gbps data rate. Copper cables can be unshielded (UTP), may have a shield embracing all the four pairs (S/UTP), there may also be a separate shield for each pair (STP) and eventual an additional shield (S/STP).

**Multimode or monomode optical fibre:** at least two fibres cable.

Optical fibre cables on horizontal cabling systems are also limited to 90 meters long, elsewhere limits are specified by the cable and connectors manufacturer together with the used layer two hardware manufacturer. Of course, we already know monomode optical fibre cables can be much longer than multimode optical fibre cables. Fibre cables maximum data rates are also dependent on upper-level technologies, starting a 1 Gbps up to 100 Gbps. Full-duplex transmission is normally granted because one fibre is used for each direction.

# Structured cabling – copper connectors

For copper cables, there is a well-defined common specification for cables terminations in TIA/EIA-568, ISO/IEC 11801 and ISO/IEC 8877 documents. These connectors are known as ISO 8877 or RJ45 (RJ stands for Registered Jack), they provide eight electric contacts matching the four twisted pairs of copper cables and an optional additional contact for shielding.

The image on the right presents an unconnected unshielded ISO 8877 female connector and a cable connected shielded ISO 8877 male connector.

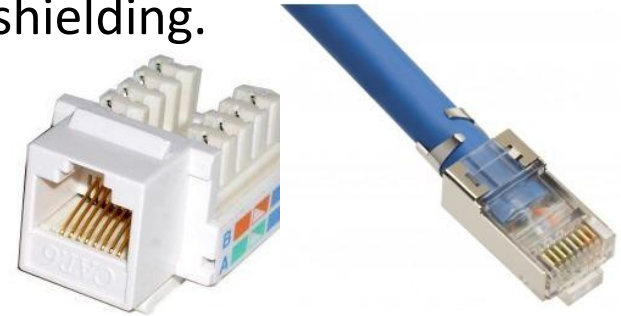

Structured cabling systems and active equipment will use only female ISO 8877 connectors; they will be latter interconnected using patch cords.

Copper patch cords are cables from 0.5 to 5 meters long with a male ISO 8877 connector on each end. They are used to connect end user equipment to work area outlets, and inside telecommunications enclosures, they are used to connect active networking devices to wiring termination hardware made of female ISO 8877 connectors.



# Structured cabling – copper patch panels

At cross-connect points a high number of cables merge, each copper cable will be connected to an ISO 8877 female connector, copper patch panels are high density mounted sets of ISO 8877 female connectors, usually a copper patch panel will have 24 or 48 ISO 8877 female connectors.



Each ISO 8877 female connector at the patch panel will be hardwired in the back to a cable leading either to the back of another ISO 8877 female connector at another patch panel on other cross-connect point, or in horizontal cabling, to the back of a work area outlet ISO 8877 female connector.

It's important to keep in mind that **all connectors and patch panels must meet the cable specifications**. If CAT7 cable is used, then all connectors, patch panels and patch cords (see next page) must be also CAT7.

# Structured cabling – copper cables wiring

Standard four pairs 100-ohm unshielded or shielded twisted-pair (CAT 5, CAT6 or CAT7) cables use a color code.

The image shows a STP cable, each pair is identified by a color: green, orange, brown and blue. All pairs are identical, but **they must be connected the same way everywhere on the cabling system.**



There are two alternative ways to connect a copper cable to ISO 8877 connectors:

T-568A or T-568B can be used, though, the chosen one should be used everywhere on the cabling system.

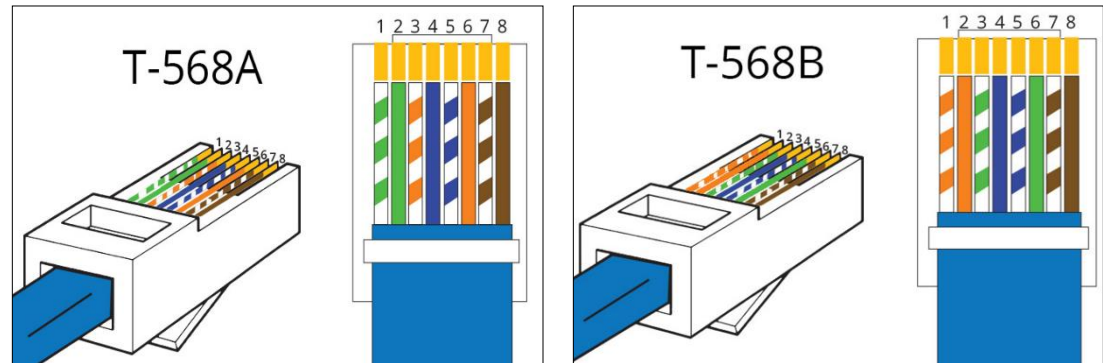

Connecting ISO 8877 female connectors is very simple because manufacturers usually place the same color codes on connectors, providing both T-568A and T-568B alternatives (left image).

# Structured cabling – fibre connectors

There are over 100 types of fibre connectors, but the following types are the most common on cabling systems:



ST  
(Straight Tip) or  
BFOC (Bayonet Fiber  
Optic Connector)



SC  
(Subscriber Connector,  
Square Connector or  
Standard Connector)



LC  
(Lucent Connector,  
Little Connector, or  
Local Connector)

They differ mainly on the mechanical attachment, the crucial component is the **ferrule**, a white cylinder with a tiny hole along the axis through where the fibre is inserted and fixed with epoxy or by heating, finally the ferrule extremity (with the fibre in it) must be polished.

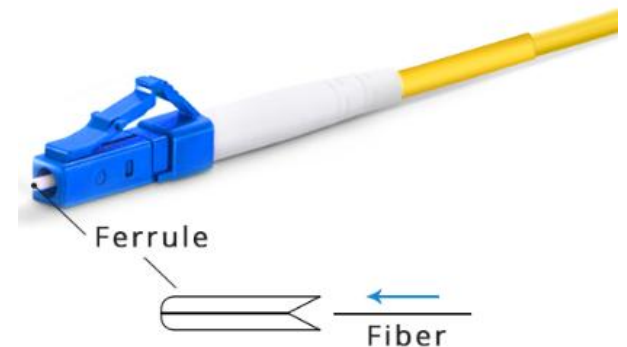

# Structured cabling – fibre connectors

The optical signal transmission between cables is achieved by facing precisely the ferrules of two cables as illustrated on the image. Female adapters (right image) are used to secure the mechanical attachment.

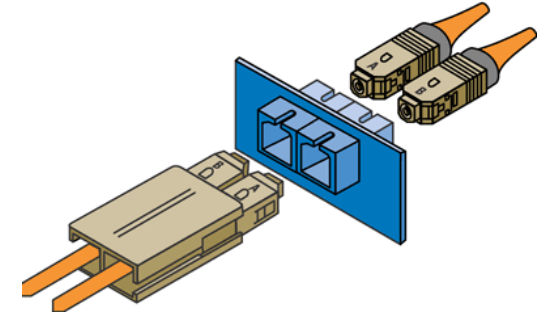

After fixing the fibre in the ferrule, the top must be polished, and there are different polish styles:



PC

(Physical Contact)



UPC

(Ultra-Physical Contact)



APC

(Angled Physical Contact)

PC and UPC are similar and compatible, basically UPC is a polish improvement over PC. **Structured Cabling and local networks (e.g., Ethernet) use UPC**, APC is used only in special cases more sensitive to return loss.

APC polish connectors are usually green, **while UPC polish connectors are usually blue**. Also, by looking carefully it's easy to tell apart an UPC polish from an APC polish.

# Structured cabling – fibre patch panels

Fibre patch panels are high density sets of female adapters providing the mechanical attachment between fibre cable connectors, images below show the exterior (left) and interior (right) of an SC patch panel.

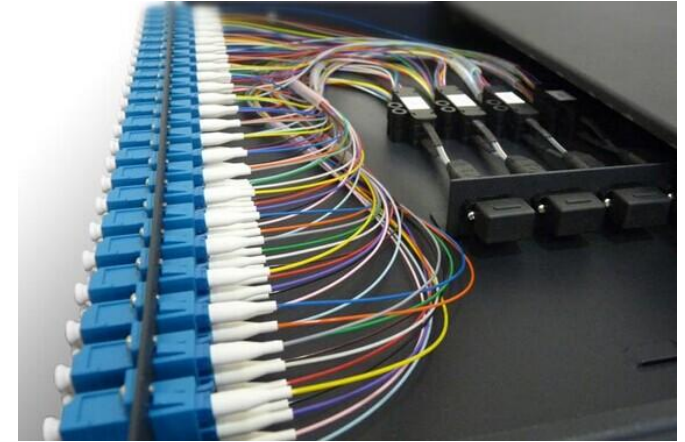

Each cable connection requires two fibres, so two connectors must be used.

Fibre patch cords (images below) are used to connect the patch panel to active equipment; a fibre patch cord may have different connector types on each end (bellow on the left side):



# Structured cabling – plans and wireless coverage

As part of a structured cabling project, plans to scale must be created showing all important structured cabling subsystems locations:

- Entrance facility, Equipment Room, and Telecommunication Rooms
- Telecommunications Enclosure and all outlets
- Cable pathways

A wireless 802.11 local area coverage is usually desired, each base station (access-point) device will grant approximately a **50 meters diameter circle coverage**.

Active devices are not part of the cabling system, nevertheless outlets to connect them are. Outlets for wireless base-stations must be placed in appropriate locations to guarantee the necessary coverage and marked on plans.

Outlets are also required at locations of other specific devices like video cameras and card readers that required a wired network connection.

# Structured cabling – rules

Each building, and each building floor, should have a telecommunications room to house an intermediate cross-connect (IC) or horizontal cross-connect (HC), however, this is not mandatory:

For instance, a single telecommunications room may house the intermediate cross-connect (IC) and the horizontal cross-connect (HC) for the floor it's in. Also, a single telecommunications room may house the horizontal cross-connect (HC) for more than one floor, this will be a reasonable solution if the number of outlets per floor is very low.

## Horizontal cabling:

- The total area covered by a horizontal cross-connect should be less than 1000 m<sup>2</sup>.
- Each cable (whatever type) length should be less than 90 meters.
- Straight line distance between the horizontal cross-connect and the outlet should be less than 80 meters.

Cables connecting an intermediate cross-connect (IC) to a horizontal cross-connect (HC) are limited to 500 meters long, and cables connecting the main cross-connect (MC) to an IC should be limited to 1500 meters long.

# Structured cabling – more rules

The number of network cables entering a telecommunications enclosure should never be above 200.

## Cabling redundancy

Each backbone connection ought to be a set of multiple parallel cables. This set of multiple cables can be used in several ways:

- Initially, use only one, if some day it fails, the operator can alternate to another one. This is called **failover** (in this case, manual failover).
- The same as before (**failover**), but automatic. Using the appropriate protocols; layer 2 (switching) and layer 3 (routing) devices detect if a cable is failing and automatically alternate to another one.
- The same as before, but all alternative cables are used at the same time to transmit data with **load balancing**. This is no longer called failover, but if a cable fails, it will no longer be used.

For the sake of paths redundancy, additional cable links should also be installed between same level cross-connects; interconnecting different ICs and interconnecting different HCs.

# Structured cabling – project development

The development of a structured cabling project must follow a precise sequence of interdependent steps:

- 1 - Requirements definition with the project owner.
- 2 - Placing network outlets on building plans.
- 3 - Placing cross-connects and defining cable pathways.
- 4 - Defining cable types to be used.
- 5 - Structure cabling hardware inventory.

# Structured cabling – project development

## 1 - Requirements definition with the project owner.

The project owner must provide a set of **at-scale building plans**.

A discussion concerning the general usage of the cabling system and the usage of each room in the plans is key.

Very high data rates (above 1 Gbps) may be required at some work areas. Some rooms may not require outlets at all, for instance, common spaces like halls and corridors. Usually, bathrooms don't have outlets.

On the contrary, some rooms may require a higher than the standard outlets per area ratio. Some additional outlets may be required for specific purposes like, for instance, video cameras and card readers.

Ideas about the Entrance facility, Equipment Room, and Telecommunication Rooms locations must be debated with the project owner. Also, information about the physical environment must be gathered: existing technical passages between floors, to exterior technical ditches, and dropped ceilings.

During next phases of the project development, the project owner should remain available for further consultation. Additional meetings should be scheduled.

# Structured cabling – project development

## 2 - Placing network outlets on building plans.

The set of **at scale building plans** is used to determine how many outlets are necessary for each room, the general rule of 2 outlets for each 10 m<sup>2</sup> is applied, though additional requirements from the previous step are considered.

Local area wireless network base-stations location and corresponding outlets must also be considered as well.

Using all this information, the outlets' locations will be then pinpointed on the building plans, inside each room outlets should be evenly distributed.

## 3 - Placing cross-connects and defining cable pathways.

Cross-connects are placed following information gathered on previous steps, trying to minimize cable lengths, standards maximum distances must be checked.

Cable pathways can then be defined taking advantage of the physical environment and trying to maximize shared portions. Standards on maximum cable lengths must then be checked.

# Structured cabling – project development

## 4- Defining cable types to be used.

Cable types definition (copper CAT6A or CAT7, multimode fibre or monomode fibre) follow two criteria: distance and data rate.

**Distance:** below 90 meters, copper cables can be used, above that, multimode fibre can usually be up to 1000 meters long, thus it will cope with all structured cabling circumstances. For longer distances, monomode fibre may be used.

**Data rate:** current layer 2 technologies over copper CAT6 are limited to 1 Gbps (CAT7 is required for 10 Gbps), higher data rates require optical fibre.

Following the principle of allowing a long time of living for the cabling system, optical fibre should be used everywhere. However, end-user equipment is not usually prepared for optical fibre outlets, thus on horizontal cabling CAT6A or CAT7 copper is usually the wisest option.

Backbone cabling systems, though, should always use optical fibre. Also, on backbone cabling multiple fibres ought to be installed, at least 8 fibres to provide 4 parallel full-duplex data links if necessary.

# Structured cabling – project development

## 5 - Structure cabling hardware inventory.

**Cables** – for each used cable type, the total cable length must be calculated. The hard work, of course, will be on horizontal cabling systems (usually CAT7), to be accurate each individual cable path length must be taken into account. Some simplifications can be applied, for instance accounting shared part of a pathway as the multiplication between that segment length and the number of cables, also for a set of cables dispersed to a room outlets a single length may be considered for all cables (the medium value, or the maximum value to be safe).

**Patch panels** – the number and types of patch panels in each cross-connect can be easily derived from the already known number of cables connected to it.

**Telecommunications Enclosures** – each cross-connect will have at least one telecommunication enclosure, 19” rack enclosures vertical size is measured in **U rack units** (1.75”/44.45 mm). Typical CAT7 24 ports patch panels have 1U size. Defining the enclosure size reflects what we already know: the patch panels that will be fitted there, but that’s not enough, active equipment will also be placed there.

# Structured cabling – project development

## 5 - Structure cabling hardware inventory.

**Telecommunications Enclosures** – if no other information about active equipment is available, an additional same space as required for patch panels should be reserved. An enclosure will be used to house numerous equipment during the cabling system lifetime, so beyond the previously value, an additional 100% oversize is wise. This means once we know the U units space required for the patch panels is **(S)**, we can reach a **(4 x S)** U units size for the enclosure. There is also the depth issue, telecommunications enclosures come with different depths, this is usually not a problem for patch panels, but it may be for higher level hardware like sophisticated switches, routers, and servers. Wall mounting enclosures usually provide an internal usable depth of around 500 mm, floor enclosures can go up to 1000 mm depth.

**Patch cords** – optical fibre and copper CAT7 patch cords required for each telecommunication enclosure equals the number of patch panel ports in each. Patch cords for enclosures should be short length, usually 0.5 meters is enough, though some longer ones may be required depending on the equipment layout. For the work area outlets, longer patch cords should be provided, up to 5 meters long.

# Structured cabling – project implementation

**Wiring CAT7** – if possible, CAT7 copper cables sets ought to be assembled off the deployment physical supports (cable conduit or tray) they will be later placed into. Each individual cable must be labelled on both ends. Cables are cut with the appropriate length and positioned together in the set accordingly to the cable pathway plan. When all cables are in the set, they can be fixed together and then the whole set will be placed on the physical support. Using shared conduits or trays for both copper communication cables (CAT7) and power cables should be avoided due to EMI (Electromagnetic Interference), they ought to be **at least 6” apart from each other**.

**Wiring fibre** – optical fibres are not installed individually as with CAT7 copper cables. Each optical fibre cable will have typically 6, 8, 12, 24, 48, and up to 144 or more fibres, so the appropriate cable must be ordered to fulfil the requirements, then a single cable will be installed on the physical support.

**Structured cabling certification** – once all cables are installed and connected, a third-party certification is required. The certification entity will use specialized equipment to measure the electric and optical characteristics of the cabling system to ensure they meet the standards.